

User Guide
6641-2201

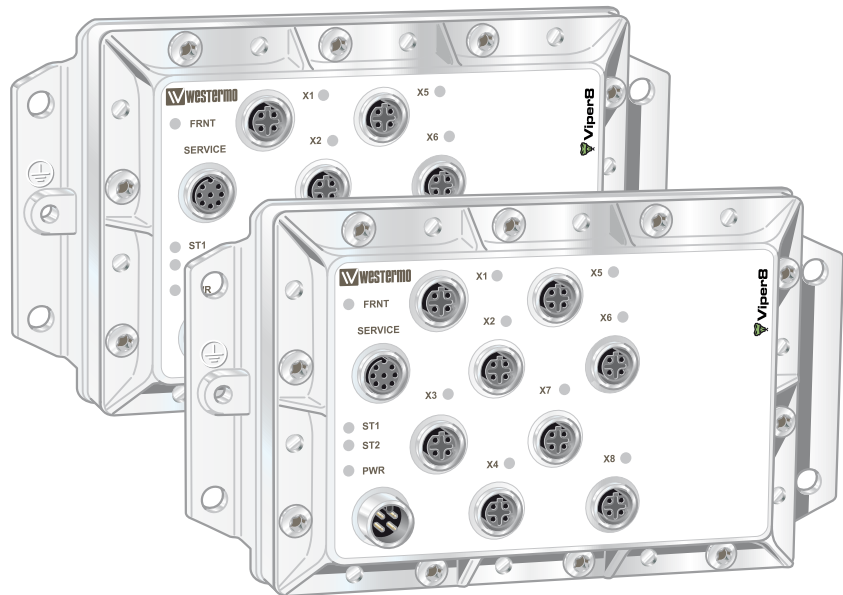

Viper

SERIES



**Managed 8-port
Ethernet Switch,**

www.westermo.com

Legal information

The contents of this document are provided "as is". Except as required by applicable law, no warranties of any kind, either express or implied, including, but not limited to, the implied warranties of merchantability and fitness for a particular purpose, are made in relation to the accuracy and reliability or contents of this document. Westermo reserves the right to revise this document or withdraw it at any time without prior notice.

Under no circumstances shall Westermo be responsible for any loss of data or income or any special, incidental, and consequential or indirect damages howsoever caused.

More information about Westermo can be found at the following Internet address:

<http://www.westermo.com>

Safety



Before installation:

Read this manual completely and gather all information on the unit. Make sure that you understand it fully. Check that your application does not exceed the safe operating specifications for this unit.

This unit should only be installed by qualified personnel.

This unit should be built-in to an apparatus cabinet, or similar, where access is restricted to service personnel only.

The power supply wiring must be sufficiently fused (e.g. Littlefuse 0461 1.25), and if necessary it must be possible to disconnect manually from the power supply. If fault contact is used, make sure that fault contact wiring is sufficiently fused.

This unit uses convection cooling. To avoid obstructing the airflow around the unit, follow the spacing recommendations (see Cooling section).



Before mounting, using or removing this unit:

Prevent access to hazardous voltage by disconnecting the unit from power supply. Warning! Do not open connected unit. Hazardous voltage may occur within this unit when connected to power supply.

Care recommendations

Follow the care recommendations below to maintain full operation of unit and to fulfil the warranty obligations.

This unit must not be operating with removed covers or lids.

Do not attempt to disassemble the unit. There are no user serviceable parts inside.

Do not drop, knock or shake the unit, rough handling above the specification may cause damage to internal circuit boards.

Do not use harsh chemicals, cleaning solvents or strong detergents to clean the unit.

Do not paint the unit. Paint can clog the unit and prevent proper operation.

Do not expose the unit to any kind of liquids (rain, beverages, etc). The unit is not water-proof. Keep the unit within the specified humidity levels.

Do not use or store the unit in dusty, dirty areas, connectors as well as other mechanical part may be damaged.

If the unit is not working properly, contact the place of purchase, nearest Westermo distributor office or Westermo Tech support.

Do not cover or bring mechanical force to the ventilation membrane on the back of the unit.

Maintenance

No maintenance is required, as long as the unit is used as intended within the specified conditions.

Agency approvals and standards compliance

| Type | Approval / Compliance |
|--------|---|
| EMC | EN 61000-6-1, Immunity residential environments |
| | EN 61000-6-2, Immunity industrial environments |
| | EN 55024, Immunity IT equipment |
| | EN 61000-6-3, Emission residential environments |
| | EN 61000-6-4, Emission industrial environments |
| | EN 50121-3-2, Railway applications - EMC: Rolling stock – Apparatus |
| | FCC part 15 Class B |
| | EN 50121-4, Railway signalling and telecommunications apparatus |
| | IEC 62236-4, Railway signalling and telecommunications apparatus |
| Safety | EN 60950-1, IT equipment |

FCC Part 15.105 Notice:

This equipment has been tested and found to comply with the limits for a Class B digital device, pursuant to Part 15 of the FCC Rules. These limits are designed to provide reasonable protection against harmful interference in a residential installation. This equipment generates, uses and can radiate radio frequency energy and, if not installed and used in accordance with the instructions, may cause harmful interference to radio communications. However, there is no guarantee that interference will not occur in a particular installation. If this equipment does cause harmful interference to radio or television reception, which can be determined by turning the equipment off and on, the user is encouraged to try to correct the interference by one or more of the following measures:

- ⌘ Reorient or relocate the receiving antenna
- ⌘ Increase the separation between the equipment and receiver
- ⌘ Connect the equipment into an outlet on a circuit different from that to which the receiver is connected
- ⌘ Consult the dealer or an experienced radio/TV technician for help.

Declaration of Conformity



Westermo Teleindustri AB

Declaration of conformity

The manufacturer Westermo Teleindustri AB
SE-640 40 Stora Sundby, Sweden

| Type of product | Model | Art no |
|-----------------|--------------|---------------------------------------|
| Ethernet switch | Viper switch | 3641-0360, 3641-0350, 3641-0340 |

is in conformity with the following EC directive(s).

| No | Short name |
|-------------|-------------------------------------|
| 2004/108/EC | Electromagnetic Compatibility (EMC) |
| 2006/95/EC | Low Voltage Directive - LVD |

References of standards applied for this EC declaration of conformity.

| No | Title | Issue |
|--------------|--|------------------------------|
| EN 55024 | Information technology equipment - Immunity characteristics - Limits and methods of measurement | 1998 +A1:2001 +A2:2003 |
| EN 61000-6-1 | Immunity for residential, commercial and light-industrial environments | 2007 |
| EN 61000-6-2 | Immunity for industrial environments | 2005 |
| EN 61000-6-3 | Emission standard for residential, commercial and light-industrial environments | 2007 |
| EN 61000-6-4 | Emission standard for industrial environments | 2007 |
| EN 50121-3-2 | Railway applications - Electromagnetic compatibility | 2006 |
| EN 50121-4 | Railway applications - Electromagnetic compatibility - Part 4: Emission and immunity of the signaling and telecommunications apparatus | 2006 |
| EN 60950-1* | Safety of information technology equipment | 2006 |

The last two digits of the year in which the CE marking was affixed: 08

Signature

Pierre Öberg
Technical Manager
3rd December 2008

* Note: Manual and safety instructions are only in English

| | | | | | | |
|---------------------------------|-------------------------------|-------------------------------|------------|-----------|----------------------------------|-------------------|
| Postadress/Postal address | Tel. | Telefax | Postgiro | Bankgiro | Org.nr/ Corp. identity number | Registered office |
| S-640 40 Stora Sundby Sweden | 016-428000 Int+46 16428000 | 016-428001 Int+46 16428001 | 52 72 79-4 | 5671-5550 | 556361-2604 | Eskilstuna |

Type tests and environmental conditions

| Phenomena | Test | Description | Test levels |
|---------------------------------------|---|---|--|
| ESD | EN 61000-4-2 | Enclosure contact | ± 6 kV (crit A) |
| | | Enclosure air | ± 8 kV (crit A) |
| RF field AM modulated | IEC 61000-4-3 | Enclosure | 20 V/m 80% AM (1 kHz), 80 – 2500 MHz (crit A) |
| Fast transient | EN 61000-4-4 | Ethernet ports | ± 2 kV (crit A) |
| | | Power port | ± 2 kV (crit A) |
| | | Earth port | ± 2 kV (crit A) |
| Surge | EN 61000-4-5 | Fault port | ± 2 kV line to earth (crit A) |
| | | Ethernet ports | ± 2 kV line to earth (crit A) |
| | | Power port | ± 2 kV line to earth, ± 2 kV line to line (crit A) |
| RF conducted | EN 61000-4-6 | Ethernet ports | 10 V 80% AM (1 kHz), 0.15 – 80 MHz (crit A) |
| | | Power port | 10 V 80% AM (1 kHz), 0.15 – 80 MHz (crit A) |
| Power frequency magnetic field | EN 61000-4-8 | Enclosure | 1000 A/m 50 Hz 300 A/m 16.7 Hz, 60 Hz, DC (crit A) |
| Pulse magnetic field | EN 61000-4-9 | Enclosure | 300 A/m (crit A) |
| Voltage dips and interruption | EN 61000-4-29 | DC power ports | 10 & 100 ms, interruption (crit A) 10 ms, 30% reduction (crit A) 10 ms, 60% reduction (crit A) +40% above & -40% below rated voltage (crit A) |
| Radiated emission | EN 55022 | Enclosure | Class B |
| | FCC part 15 | | Class B |
| Conducted emission | EN 55022 | DC power port & Ethernet ports | Class B |
| | FCC part 15 | DC power port | Class B |
| Dielectric strength | EN 50155 | Ethernet ports to other isolated ports | 707 VDC 1 min |
| | | Power & Fault port to other isolated ports | 2121 VDC 1 min |
| Temperature | | Operating | -40 to +70°C |
| | | Storage & Transport | -40 to +70°C |
| Humidity | | Operating | 5 to 95% relative humidity |
| | | Storage & Transport | 5 to 95% relative humidity |
| Altitude | | Operating | 2000 m / 70 kPa |
| Reliability prediction (MTBF) | MIL-HDBK- 217F | Operating | Ground Benign: 103 years @ 20°C 100 years @ 40°C 90 years @ 60°C Ground Mobile: 5.92 years @ 20°C 5.91 years @ 40°C 5.88 years @ 60°C |
| Service life | | Operating | 10 year |
| Vibration, random simulated long life | IEC 60068-2-64, Cat. 1 class B (EN 61373) | Not Operating | Vertical: 7.9 m/s ² Transverse: 7.9 m/s ² Longitudinal: 7.9 m/s ² 3 x 5 h |
| Vibration, random functional | IEC 60068-2-64, Cat. 1 class B (EN 61373) | Operating | Vertical: 1.0 m/s ² Transverse: 1.0 m/s ² Longitudinal: 1.0 m/s ² 3 x 10 min |

| Phenomena | Test | Description | Test levels |
|-------------------------|--|--------------------|---|
| Shock, half sine pulses | IEC 60068-2-27, Cat. 1 class B (EN 61373) | Operating | Vertical: 50 m/s ² Transverse: 50 m/s ² Longitudinal: 50 m/s ² 30 ms, 3 x 6 shocks |
| Shock, sawtooth | IEC 60068-2-27, Cat. 1 class B (IEEE1478-2001) | Operating | Vertical: 100 m/s ² Transverse: 100 m/s ² Longitudinal: 100 m/s ² 11 ms, 3 x 6 shocks |
| Enclosure | UL 94 | Nickel coated zinc | Flammability class V-1 |
| Dimension W x H x D | | | 175 x 100 x 50 mm |
| Weight | | | 0.8 kg |
| Degree of protection | IEC 529 | Enclosure | IP 65 when all ports are protected/ connected else IP 40 |
| Cooling | | | Convection |
| Mounting | | | Wall mounted |

Description

Functional description

Viper is a range of switches consisting of two different function levels developed for rail and industrial applications. To meet the environmental requirements from rail and harsh industrial applications the switch has rugged M12 Ethernet connectors and full metal housing. The switch fulfills IP 65 degree of protection when all ports are protected/connected else IP 40. Our unique FRNT (Fast Recovery of Network Topology) technology is the fastest protocol on the market to re-configure a network in the event of any failure of a link or hardware. Real-time properties are implemented in the Viper-series in order to achieve determinism for real time critical applications. The Viper-switches support QoS (Quality of Service) with four priority queues and strict priority scheduling as well as HoL (Head of Line Blocking Prevention). All to assure that the data network is deterministic.

Interface specifications

| Power and fault relay port PWR | |
|----------------------------------|--|
| Rated voltage | 24 to 110 VDC |
| Operating voltage | 24 to 110 VDC ±40% |
| Rated current | 40 mA @ 110 VDC 140 mA @ 24 VDC |
| Rated frequency | DC |
| Inrush current, I ² t | Max 0.02 A ² s @ 24 – 110 VDC |
| Startup current * | 7 A _{peak} @ 24 – 110 VDC |
| Polarity | Reverse polarity protected |
| Redundant power input | No |
| Isolation to | Connections X1 – X8 and to ground, 1500 VAC. Fault relay belongs to the same isolation group as the power supply lines (fault relay signals are also contained within PWR). |
| Connection | 4 pin male M12 connector with A-code |
| Connector size | M12, recommended cable area 0.5 mm ² recommended (minimum 0.25 mm ²), cable dimensions depend on choice of M12 connector |
| Shielded cable | Not required, twisted pair is recommended |
| Fault relay resistance | < 10 Ω |
| Operating voltage | Up to 110 VDC |
| Max continuous current | 250 mA |

* If external power supply is used it must meet specified startup current.

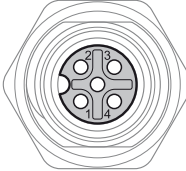
|  M12 A-Coded Power Connector | Position | Direction | Description |
|--|----------|-----------|-----------------------------|
| | 1 | U+ | Positive supply voltage |
| | 2 | Out | Alarm relay (status) + |
| | 3 | 0V | Negative supply voltage |
| | 4 | Out | Alarm relay (status) – |
| | Housing | Shield | Chassis of product (ground) |

Fault Contact

The Viper switch is equipped with a potential free normally closed fault contact. The fault contact is a solid state component (relay) that requires power to work and it is transient protected. Additionally, the fault contact is opened when any of the following conditions is met:

- No voltage on the power supply pin, a voltage level outside the legal voltage range or current limitation on the voltage source is applied on the power input.
- Link alarm i.e. missing link on any Ethernet port that has link alarm enabled.
- Redundancy Mode activated i.e. one or more FRNT link is down.

Description of how connection to the fault contact could be done is shown below.

The relay is closed when the unit is OK and open at failure. The relay is of semiconductor type (no moving parts). It is specified for max current 250 mA continuous, 500 mA peak (10 ms), operational voltage up to 110 V, protected by a 150 VDC-varistor, ON-resistance less than 10 Ohm, and leakage current max 1 μ A.

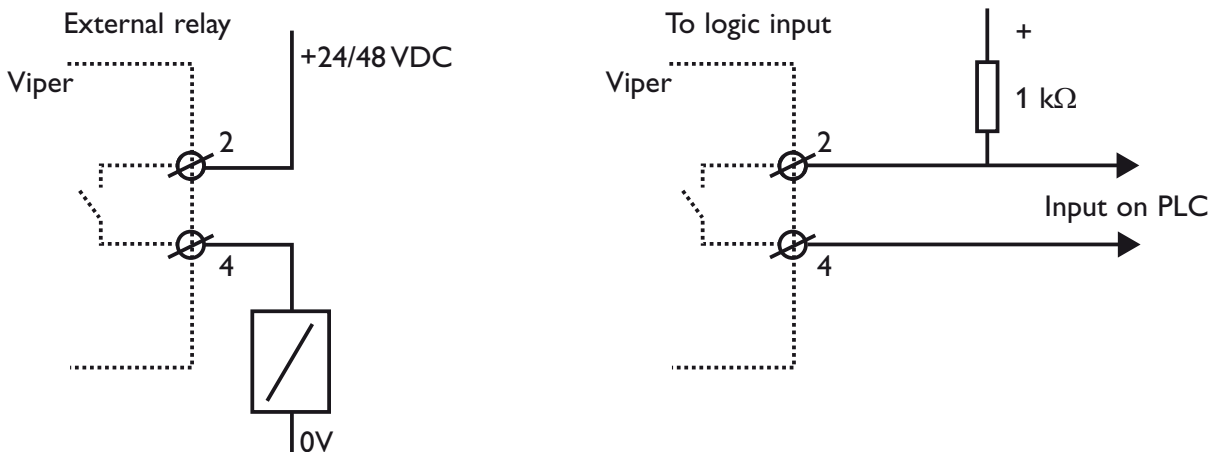

Service port

The Service Port should not be used by non other than the Westermo Technical Support team. Do not connect any device or cable to the Service Port.

| Ethernet TX port X1 to X8 | |
|----------------------------------|---|
| Electrical specification | IEEE std 802.3. 2000 Edition |
| Data rate | 10 Mbit/s or 100 Mbit/s, manual or auto |
| Duplex | Full or half, manual or auto |
| Circuit type | TNV-1 |
| Transmission range | 150 m |
| Isolation to | Other Ethernet ports, 500 VAC PWR, 1500 VAC |
| Galvanic connection to | None, except for shielded contact to housing |
| Connection | 4-pole M12 female with D-code |
| Shielded cable | Not required, twisted pair is recommended |
| Conductive housing | Nickel plated zinc, metal housings of X1-X8 also connected to the housing |
| Number of ports | 8 Ethernet (X1-X8) |

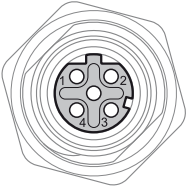
|  | Position | Direction | Description |
|--|-----------------|------------------|-----------------------------|
| | 1 | Out | Transmit Data + |
| | 2 | In | Receive Data + |
| | 3 | Out | Transmit Data – |
| | 4 | In | Receive Data – |
| | Housing | Shield | Chassis of product (ground) |

Location of Interface ports, LED's

LED indicators

| LED | Status | Description |
|----------|-------------|--|
| PWR | GREEN | Unit indicates no fault |
| | RED | Unit indicated fault |
| | FLASH | Connected to IP Configuration tool |
| FRNT | OFF | FRNT is not enabled or not supported |
| | GREEN | FRNT is running and the switch is configured as member switch in the ring. |
| | GREEN FLASH | FRNT is running and the switch is configured as Focal Point |
| | RED | FRNT Error |
| ST1 | GREEN | Indicates STP root |
| ST2 | NC | |
| X1 to X8 | OFF | No Link |
| | GREEN | Link is up |
| | GREEN FLASH | Data is transmitted |
| | YELLOW ON | Port larm and no link. If RSTP/FRNT mode are activated, port is blocked. |

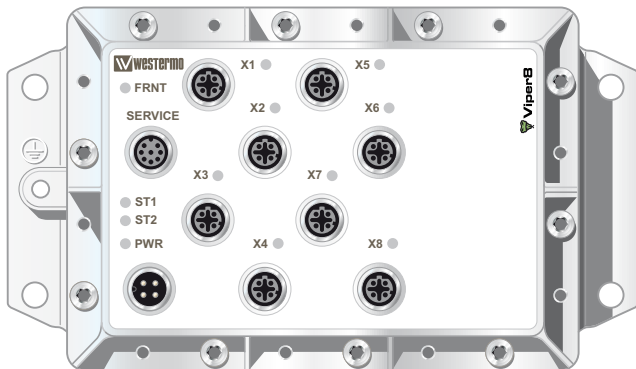

Configuration

The units can easily be configured via the onboard Web based configuration tool. Local IP addresses can also be configured by using the Westermo IP Configuration tool, from the IP Configuration tool it is then possible to browse into the unit for further configuration.

IP Address

When delivered, the default IP address of the Viper is 192.168.2.200.

Default gateway 192.168.2.200

If the default address of the unit is valid in the connected network it is possible to access the unit directly from a web browser.

Change local IP address

The local address of Viper can be configured using the IP Configuration tool, then it is possible to browse into the unit for further configuration. The IP Configuration program is available on the CD or for download from the WESTERMO web page:

<http://www.westermo.com>, choose Downloads/Software/Ethernet/Ethernet switches

Name: IP config Westermo.zip

Install the software and start the application from a PC on the network connected to the same network as the Viper. Make sure that the Default IP of the configuration software (see figure below) is in the same subnet as your PC.

Note! If you are not sure about the subnet – consult your network administrator.

Note! IP Config version must be 10.0.0 or higher.

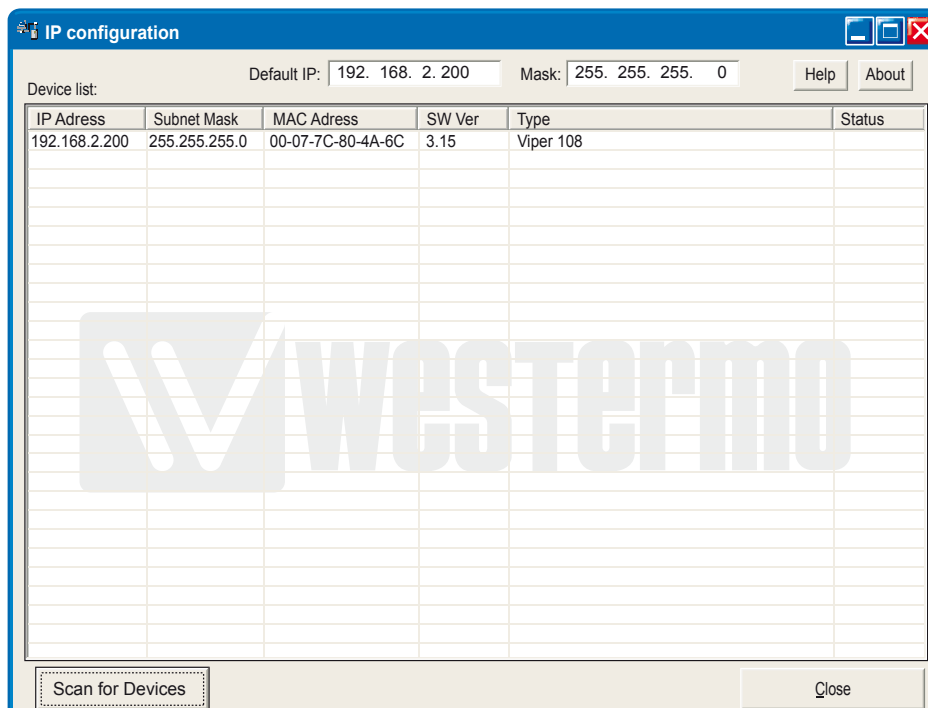

Figure 1

By clicking the “Scan for Devices” button the IP Configuration tool will detect the switches/routers in the network. The software will list all Westermo managed switches or routers connected to the network. Information as in the figure 1 will appear for each detected unit connected to the same network as your PC.

If you only want to change the IP address and the subnet mask, this can be done within the IP config tool.

By clicking the listed Viper that you wish be re-configured you will be asked if you would like to access via web figure 2. Click the abort button, enter the preferred IP address, Subnet mask and IP gateway address and click the Set button to confirm the settings in the unit (see figure 3).

Note! If you are not sure about the settings – consult your network administrator.

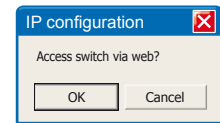
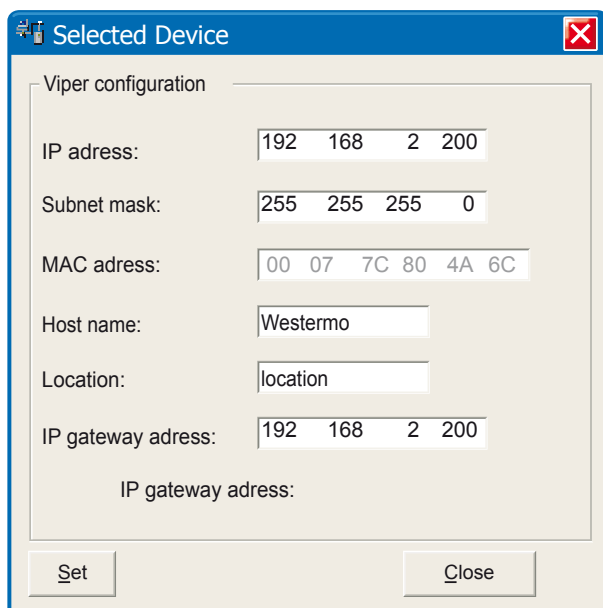

Figure 2



Click the Close button to get back to main view. You will then be asked if you would like to quit. Click the OK button, figure 4, and you will be back to the main view of the IP Configuration program(see figure 1).

Figure 3

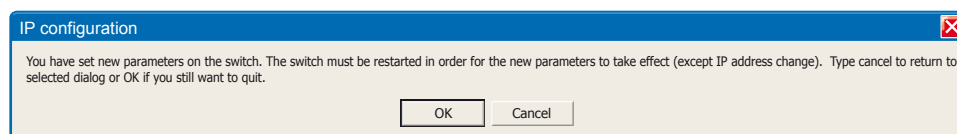
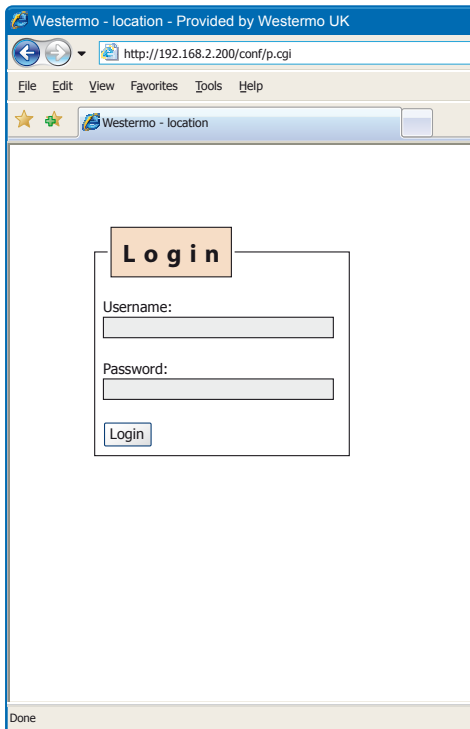

Figure 4

Click the Scan for switches button again and the settings you configured will appear in the list. Now you can access the Viper via the browser for further configuration by clicking the unit with an IP address that fits your subnet. Figure 2 will appear and when you click the OK button and a web browser will be opened and redirected to the Viper unit log in page (see figure 5).



Log in via Web

You will be prompted with a Login screen where the default settings for Username and Password are:

Username: admin

Password: westermo

Figure 5

The unit can be easily configured via the on-board Web based configuration tool. The network interface and switch properties can be configured and stored. The Web tool also has an extended integrated help function describing all configuration options.

Note! Max 10 characters can be used in the login.

Note! For login the following characters are not valid.

ASCII 34 = "

ASCII 35 = #

ASCII 39 = ”

ASCII 40 = (

ASCII 92 = \

Mounting

There are four 6 mm bore holes intended for mounting the unit. The unit can be mounted vertical or horizontal. The unit is wall mounted.

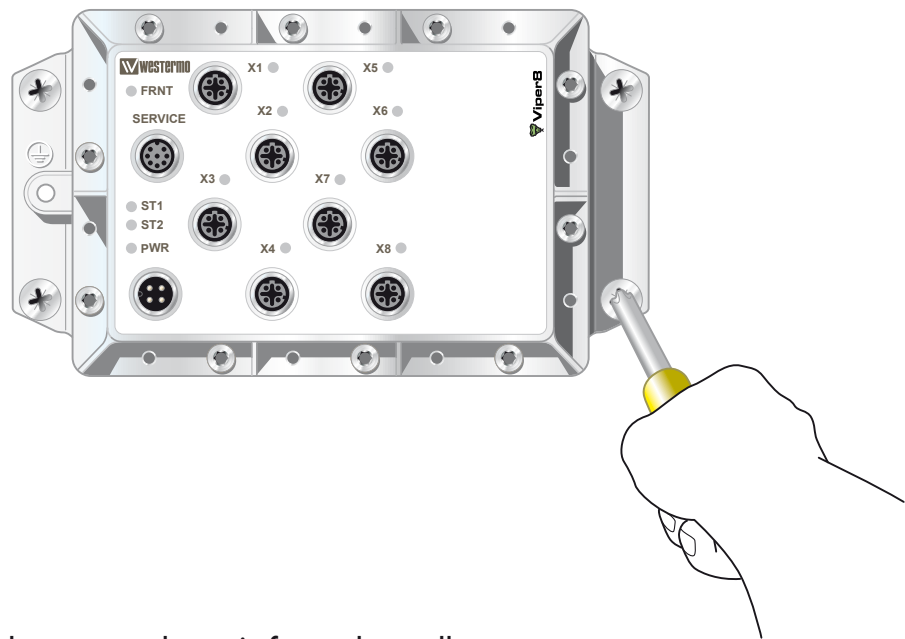

Removal

Disconnect all cables and unscrew the unit from the wall.

Cooling

This unit uses convection cooling. Avoid obstructing the airflow around the unit. Spacing is recommended for the use of unit in full operating temperature range and service life.



Westermo Teleindustri AB • SE-640 40 Stora Sundby, Sweden
Phone +46 16 42 80 00 Fax +46 16 42 80 01
E-mail: info@westermo.se
Westermo Web site: www.westermo.com

Subsidiaries

Westermo Data Communications AB
Svalgången 1
SE-724 81 Västerås
Phone: +46 (0)16 42 80 00 • Fax: +46 (0)21 35 18 50
info.sverige@westermo.se

Westermo Data Communications Ltd
Talisman Business Centre • Duncan Road
Park Gate, Southampton • SO31 7GA
Phone: +44(0)1489 580-585 • Fax: +44(0)1489 580586
E-Mail: sales@westermo.co.uk

Westermo Data Communications GmbH
Goethestraße 67, 68753 Waghäusel
Tel.: +49(0)7254-95400-0 • Fax: +49(0)7254-95400-9
E-Mail: info@westermo.de

Westermo Data Communications S.A.R.L.
9 Chemin de Chilly 91160 CHAMPLAN
Tél : +33 1 69 10 21 00 • Fax : +33 1 69 10 21 01
E-mail : infos@westermo.fr

Westermo Data Communications Pte Ltd
2 Soon Wing Road #08-05
Soon Wing Industrial Building
Singapore 347893
Phone +65 6743 9801 • Fax +65 6745 0670
sales@westermo.com.sg

Westermo Teleindustri AB have distributors in several countries, contact us for further information.